

Flat-shape ultrasonic module

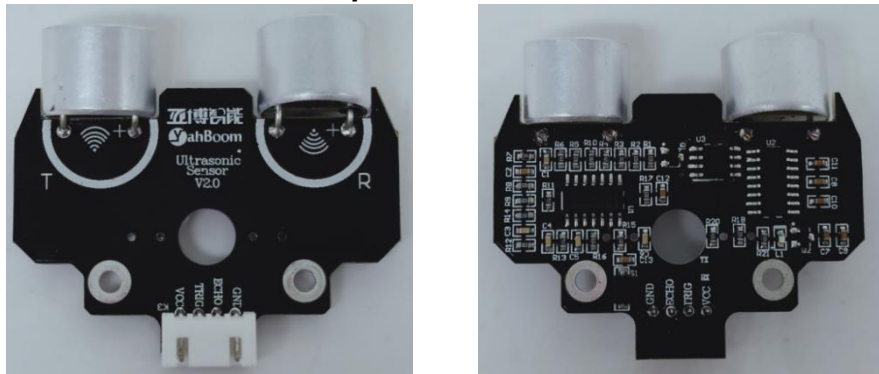

1. Description of Pin

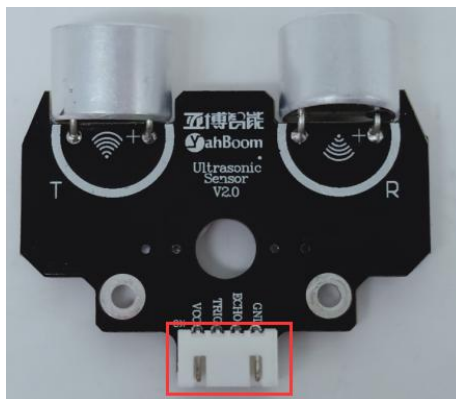

1-1 Position of Pins

The anti-reverse socket is used here, and it can be connected by cable or DuPont wire.

Name of Pin	Description
VCC	5V power supply
GND	GND
TRIG	Trigger pin
ECHO	Feedback pin

2. Sender

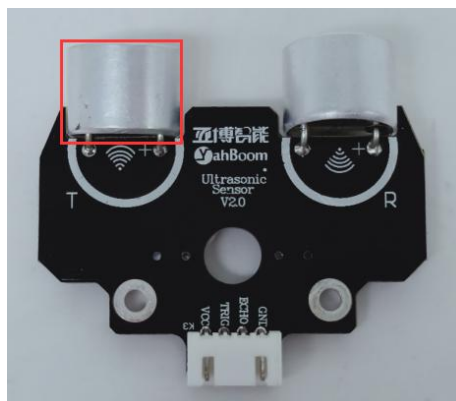

2-1 Position of sender

This interface is an ultrasonic transmitter used to transmit ultrasonic signals.

By inputting a high level signal of at least 10 us to the TRIG pin of the ultrasonic module, the ranging function of the ultrasonic module can be triggered.(A high level of 15us is recommended)

3.Receiver



3-1 Position of Receiver

This interface is an ultrasonic receiver used to receive ultrasonic signals. Working principle: After the ranging function is triggered, the module will automatically send out 8 40 kHz ultrasonic pulses and automatically detect whether there is a signal return. This step is automatically completed by the module. The ECHO pin will output a high level once an echo signal is detected. The high level duration is the time from the transmission to the return of the ultrasonic wave.

4.MCU

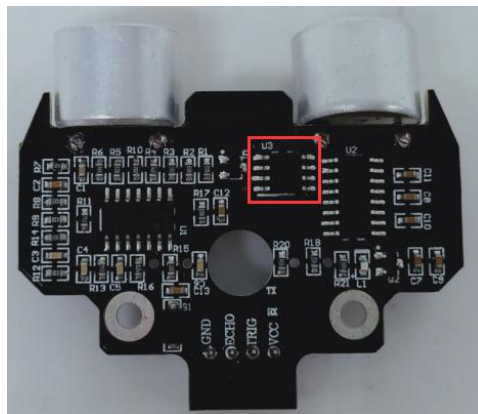

4-1 Position of MCU

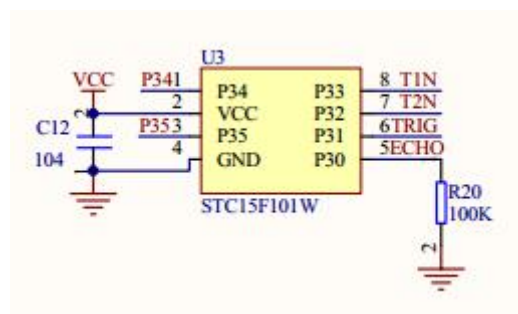

4-2 Schematic

This is the master chip of ultrasonic.

5. Chip of sending signal

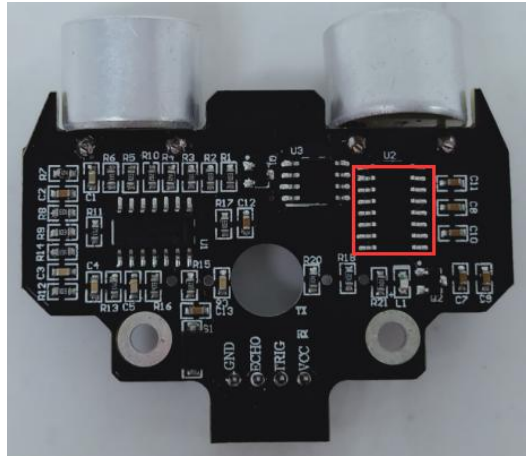

5-1 Position of chip

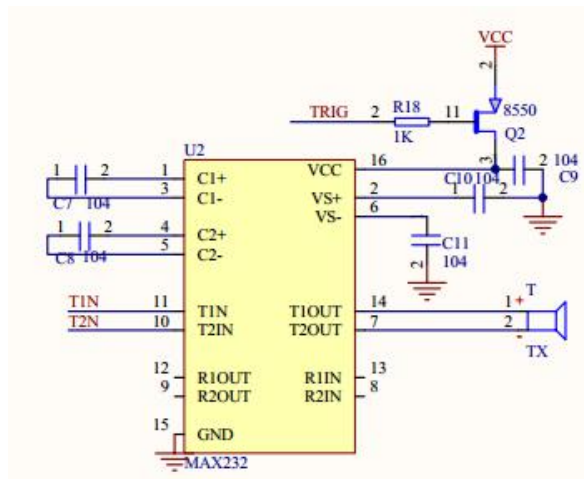

5-2 Schematic

This chip is used to drive the transmitter to send out ultrasonic signals.

6. Chip of receiving signal

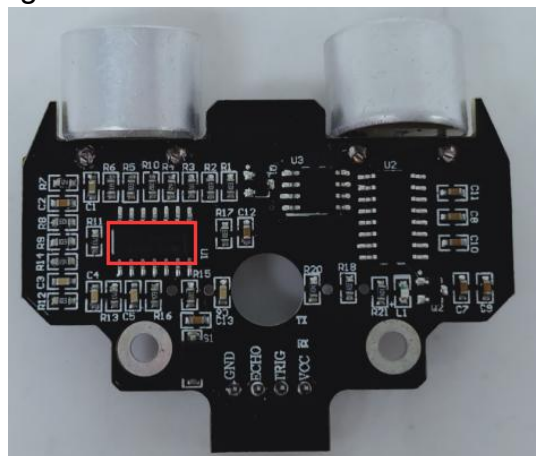

6-1 Position of chip

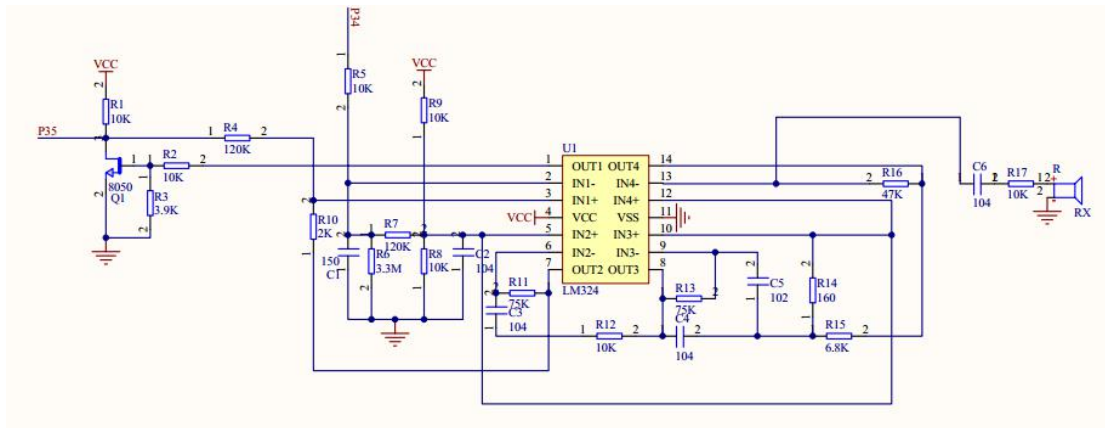

6-2 Schematic

This chip is used to receive and process ultrasonic echo signals as well as give feedbacks to the master chip.

Hardware connection: (The definition of the pin can be changed in the program by yourself)

1. Connection with Arduino:

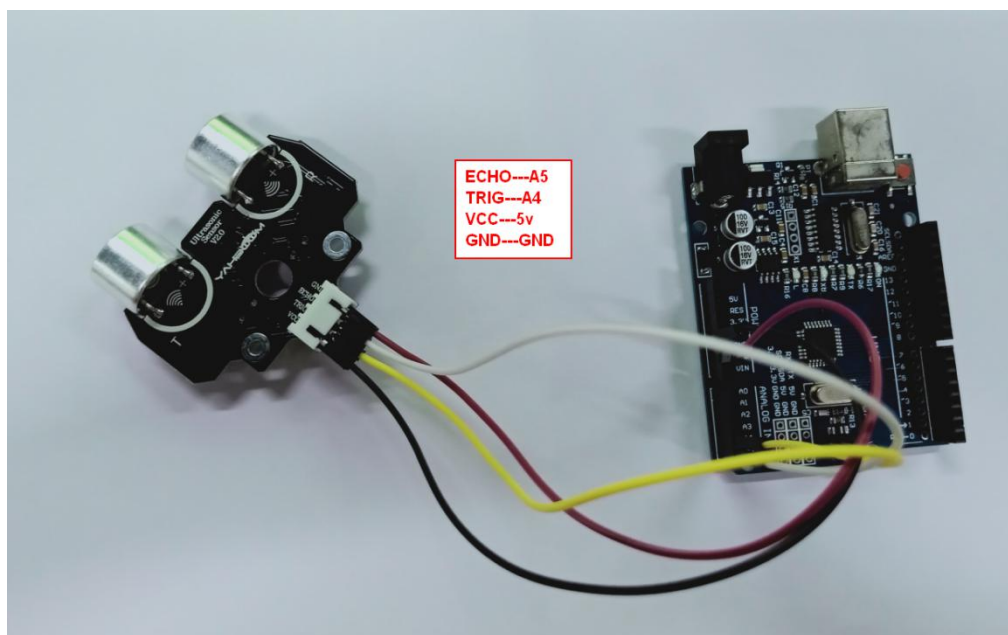

Note:

1. This module should not be directly connected with power. If you want to connect with power, you need to connect the GND pin of the module at the first, otherwise it will affect the normal operation of the module.
2. When measuring distance, the measured object should be no less than 0.5 square meters and the plane should be flat as much as possible, otherwise the measurement result will be affected.

We will provide Arduino, Raspberry, Micro:bit driver source code.